

GOVERNMENTAL SERVICES STANDING COMMITTEE

Regular Meeting
City Hall Conference Room
August 10, 2010

ATTENDANCE

The meeting began at 8:00 a.m. with the following in attendance: Council members Campbell, AlMBERG and Palmer.

Others present: Mayor Slowik, City Administrator, Paul Schmidt; Development Services Director, Steve Powers, Senior Planner, Cac Kamak; City Engineer, Eric Johnston; Senior Services Director, Mike McIntyre; and Harbormaster, Mack Funk.

PUBLIC COMMENT

None present for comment.

REVIEW OF JULY 13, 2010 MEETING NOTES

No questions or comments.

PLANNING

Pioneer Way Improvements Project

Mr. Johnston provided handouts attached to these notes as Attachment 1. Mr. Johnston explained that the handouts are reflective of changes that were made following the comments that were received in June. Mr. Johnston reported the following:

- Drop-in sessions are scheduled for tomorrow and Saturday at Angelo's Café. The sessions are informal and hopefully the merchants will come and talk about the status of the project and staff will gather more information from the merchants in order to put finishing touches on the construction scheduling.
- The renderings are reasonably accurate to what the design plan will be and will be posted on the bulletin board downtown.
- In the next two to three weeks subconsultants to Perteet will be visiting several businesses to evaluate what it will take and what it will cost to underground power to the businesses and provide this information to the property owners so they will have an idea of what it will cost when the conversion takes place next summer.
- The City received the 60% design plan and staff will have those available at the drop-in sessions.
- The underground power design by PSE is moving forward and once they are done staff will be in contact with Comcast and Verizon.
- Mr. Powers noted that the Shoreline Substantial Permit is scheduled for public hearing before the Planning Commission on August 24th and will come to the Council as a closed record review in September. The reason for the permit is because approximately 200 feet of the improvements are within the shoreline jurisdiction.
- Mr. Johnston noted that there are four locations set aside for future public art.

Discussion

Committee questions:

- Is there a theme for the art? Mr. Johnston stated that staff is working with the Arts Commission regarding a theme.
- Where did the 30 extra parking spaces come from? Mr. Johnston explained that if the City decides that we have the funding to build the additional parking, a right-of-way purchase from the property owner will be necessary. The design includes the extra parking as part of the project but we can decide not to cut that area out as parking if funding is not available.

- Will the extra parking diminish the use of the property? Mr. Johnston stated that it would not.
- What is the total amount of parking? Johnston stated that 128 parking spaces are shown in the drawing.
- Is the cost still the same and has the time schedule changed? Mr. Johnston stated that it is still 8.3 million and the schedule is the same.
- Did the bike lane go away? Mr. Johnston stated that it is still wide enough for bikes but it is not wide enough to stripe and designate as a bike lane.
- Are awnings and overheads affected? Mr. Johnston stated they would not be affected.

Wallin-Goldie Road Annexation

Mr. Powers reported that petitions are coming in and he anticipates having them by the end of the month and then the petitions will be sent to the County for the required determination of sufficiency. The determination will take approximately 30 days. It will be at least the end of September or early October before we get a determination from the County and then the Council might be able to consider the annexation in December.

Discussion

Committee questions:

- Will the stormwater rates be phased in? Mr. Powers said that proponents are free to make that request of the Council. A spreadsheet has been provided to Mr. Wallin on behalf of the property owners that show what the City anticipates the monthly and annual charges will be based on the proposed stormwater rate and based on the propose number of square feet of an equivalent residential unit.

Adult Entertainment Ordinance

Mr. Kamak explained that the City adopted an interim ordinance in March which is in effect for six months and will expire in September. The RCW provides for extending the interim ordinance but a work plan must be filed. Staff has devised a work plan which identifies the tasks that staff is working on. The tentative work plan is to conduct further research on locating adult entertainment facilities. Staff is focusing on secondary effects of the adult entertainment business which will form the evidence base to which the regulations will be formulated. Studies from approximately 30 cities related to secondary effects of adult entertainment facilities to the Planning Commission. The Planning Commission will narrow down the options (concentrated vs. dispersion). Once options have been narrowed, studies specific to the option must be provided so that specific secondary effects can be identified. This will help to tailor the regulations to mitigate the secondary effects. The second part of the work plan is to formulate regulations that are designed so that the preferred location for the overlay zone provides a reasonable opportunity for the adult entertainment facilities to open and operate.

The tentative schedule in the work plan is as follows:

August 2010 – October 2010	Public Hearings before the Planning Commission and narrowing down the location and performing site specific studies to justify the legal requirements
November 2010 – December 2010	Provide 60 day notification to Department of Commerce
November 2010	SEPA review and Determination.
December 2010	SEPA Determination Public Comment Period
January 2011	Government Services Committee
January 2011 – February 2011	Public Hearing before the City Council

Discussion

Committee questions:

- Can the interim ordinance be extended another six months if necessary? Mr. Kamak stated that we are allowed two six month extensions from the original adoption of the interim ordinance. Mr. Powers stated that staff didn't anticipate the need for a second six month extension.

West Meadows Final Plat Alteration

Mr. Powers stated that this item will go before Council in September. The West Meadows project is at Airline Way and Crosby Road. There is a request from the developer for an alteration of the final plat. The alteration pertains to a single lot (lot 54) which is a corner lot. The developer is requesting that the access to the lot be changed from corner shown on the original plat to the other corner. From staffs perspective it is a non-issue but only the Council has the authority to modify a final plat. The engineering department has also reviewed the request and they are confident that alteration meets the original requirements of the plat.

MARINA

Marina Redevelopment Project Phase 2 Dredging

Mr. Powers reported the project is out to bid and bid opening is August 18th. The bid that was authorized includes the base bid and add alternate 1 which is under the breakwater F Dock area and then includes a quantity inside of the bid alternate area 2 that the engineers felt was a good quantity (13,000 cubic yards) to be reflective of getting a good quantity price. Council has great flexibility within add alternate 2 in the way that the special provisions of the bid document is written. It provides the Council a swing of up to 35% plus or minus over the 13,000 cubic yard quantity. It is a means by which we can establish a per unit price for that area. If it is a good unit price we can add to that quantity and if it's not a good price we can deduct from that quantity.

Mr. Funk had a pre-bid walk-through and there were representatives from four contractors that participated.

Discussion

Committee questions:

- Is staff re-evaluating the fee schedule to more closely match the fees in Anacortes? Mr. Powers indicated that staff is doing so.
- Is staff evaluating whether or not to charge the general public for use of the pier for launches etc.? Mr. Powers stated that staff is looking at fees for commercial use of the marina but not recreational use. The marina is a public marina and the City has a lease with a public agency to utilize the tide land and we have some obligation to provide public access which is often times without charge as opposed to someone that pays for exclusive use of a space year-round. Staff is not sure that the City can charge for general public use but staff is looking at the issue.
- Is staff allowed to call and follow-up with prospective bidders to find out if they are going to bid? Mr. Johnston stated that it is preferable not to have contact with one contracted versus others. We try to avoid an indication that a bidder can come back to the City and say that there was communication with another bidder that was outside of the normal process that everyone had.

General Marina Update

Mr. Funk reported:

- Channel navigation aids were updated last week.
- Anacortes refineries are only producing fuel with ethanol. The next delivery of gasoline with ethanol. The Marina is informing customers through the newsletter and a number of signs. The Marina Advisory Committee was also briefed.

Discussion

Committee questions:

- What is the advantage or drawbacks to ethanol? Mr. Funk stated one of his customer said he has been using ethanol for a year and hasn't had any problems. The advantage is that the fuel is better for the environment. The marine engine manufacturers state unequivocally that ethanol is satisfactory.

SENIOR SERVICES

HVAC Replacement

Mr. Powers reported that a mechanical engineer evaluated the units and determined the City is on borrowed time because the expected major component service life is 18 years and the system is 24 years old. Maintenance costs are rising and replacing the units should be considered so that it can be done in a controlled fashion.

Discussion

Committee questions:

- Do we plan on replacing the building in the near future? Mr. Johnston indicated that there are no plans to replace the building.
- What is the proposed budget/engineer's estimate? Mr. Johnston stated that it was between \$60,000 and \$80,000 but the engineer is still working on the estimate.

ADMINISTRATION

2011 – 2012 Strategy Statement

Mr. Schmidt reported that the strategy statement is a product of the 2010 City Council retreat conducted on February 27, 2010. The purpose is to provide a springboard for the 2011-2012 Budget. It is a tool to communicate to the community what the City's goals are. Twenty-two goals are listed along with an action plan and a strategic financial plan. The strategic financial plan will be presented and the Finance Committee meeting. Mr. Schmidt asked the Committee to let him know if anything should be changed.

Discussion

Committee questions:

- How can we say today, that we will continue the trend of General Fund expenditures at 45 to 5.5%? If things change the numbers will change a lot. Committee members also commented that the message is that the City is watching these areas and is focusing on the trends.
- What is the status of the animal shelter facility? Mayor Slowik stated that the City just sign a lease with the Navy last week and WAIF will be able to move in within the next 30 to 45 days based on how quickly the Navy can get the building prepared.
- Is the City providing support for low income housing legislatively and should it be on our list of goals? Mr. Schmidt stated that the goal of providing support for low income housing is on the Legislative Priorities list but City Council can add it to the 2011 – 2012 Strategy

Statement goals. Mayor Slowik added that the State has suggested to the County to combine the homeless housing committee and affordable housing committees as well as the funds for those programs. It is more of a county issue than a city issue.

- Has there been any discussion with the Navy about using one of the buildings they are planning to tear down as short term shelter. Mayor Slowik said there has been no discussion. Mr. Slowik noted that the reason the Navy is assisting with providing an animal shelter facility is because the City provides animal control for them.

2011 Legislative Priority Issues

Mr. Schmidt reported that this agenda item will come before the City Council September 21st. Mr. Schmidt explained that he had crossed out the priorities that are not pertinent this year and 14 through 17 are new. The list is subject to change by Council.

Committee Discussion

- Committee members were glad to see added to the list support of a Legislative effort to begin planning for the definite replacement of the Deception Pass Bridge.
- If we lose the CAPRON funds what dollar amount is that to Public Works operations? Mr. Schmidt stated that it was around \$750,000. Mr. Johnston said the CAPRON funds are lost the City will essentially have to fund the Streets Division out of the General Fund. The concern is that only San Juan County and Island County are the only counties that get CAPRON funds so there is the potential for the Legislature to cut those funds.

Mr. Schmidt noted that the items on the list are not listed in any order or weighted in any way.

Development Services Director's Comments - none

NEXT MEETING: September 14, 2010

MEETING ADJOURNED - 9:17 a.m.

Current design plan

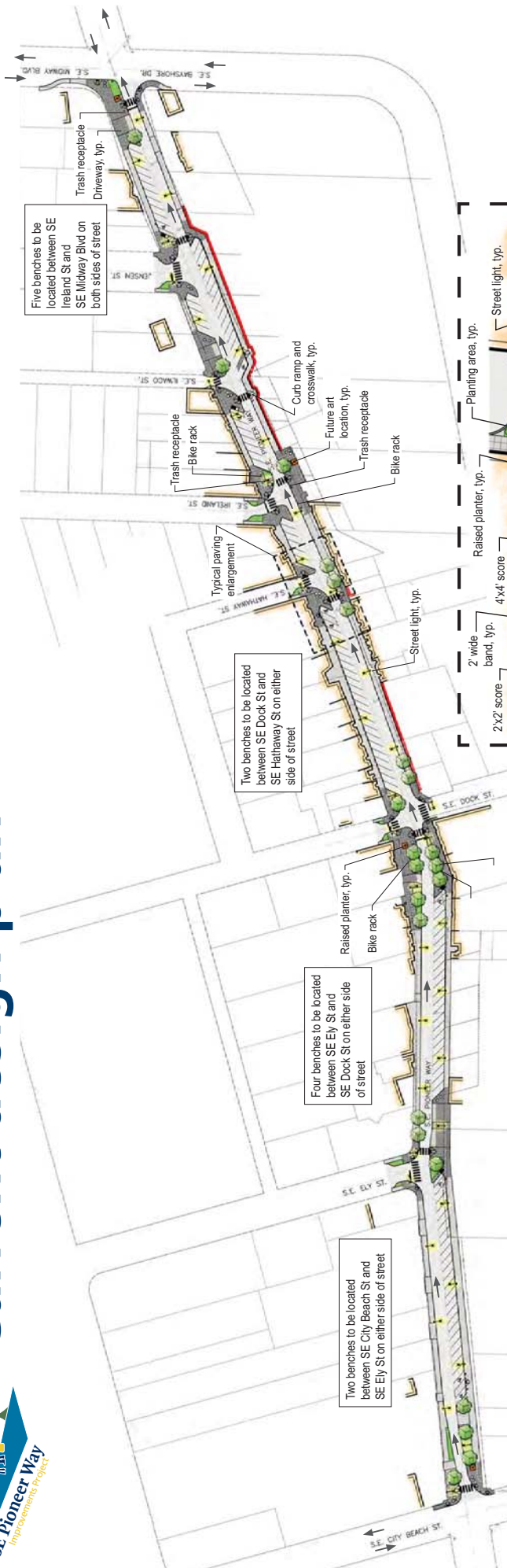

LEGEND

- Street Tree
- Standard Sidewalk
- Accent Sidewalk
- Landscape Area
- Street Light
- Crosswalk
- Driveway
- Existing Building
- Future Art Location
- Raised Planter
- Metal Railing

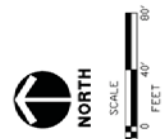
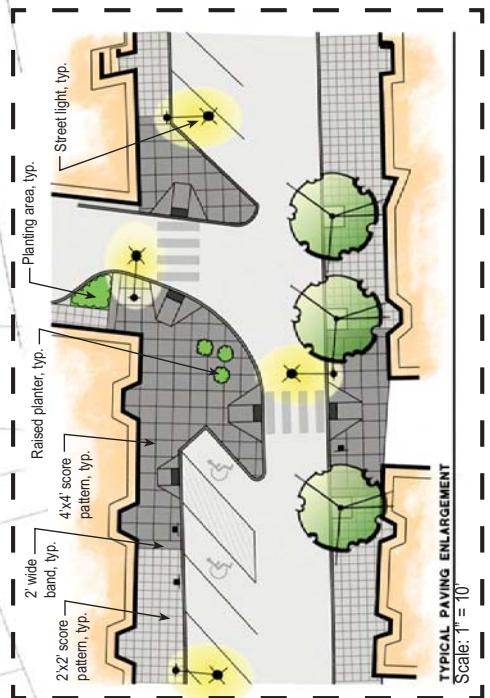



Street rendering



Intersection of SE Pioneer Way and SE City Beach Street looking east

Street renderings are intended for visualization purposes. Final street signage and additional design detail will be part of contractor documents.



Design drop-in sessions: August 2010



Street rendering



Intersection of SE Pioneer Way and SE Ely Street looking east

Street renderings are intended for visualization purposes. Final street signage and additional design detail will be part of contractor documents.



Design drop-in sessions: August 2010



Street rendering



SE Pioneer Way looking east

Street renderings are intended for visualization purposes. Final street signage and additional design detail will be part of contractor documents.



Design drop-in sessions: August 2010



Street rendering



SE Pioneer Way looking east

Street renderings are intended for visualization purposes. Final street signage and additional design detail will be part of contractor documents.



Design drop-in sessions: August 2010



Street rendering



Intersection of SE Pioneer Way and SE Midway Boulevard looking west

Street renderings are intended for visualization purposes. Final street signage and additional design detail will be part of contractor documents.



Design drop-in sessions: August 2010



Street rendering



SE Pioneer Way looking west

Street renderings are intended for visualization purposes. Final street signage and additional design detail will be part of contractor documents.



Design drop-in sessions: August 2010



Street rendering



Intersection of SE Pioneer Way and SE Dock Street looking west
Street renderings are intended for visualization purposes. Final street signage and additional design detail will be part of contractor documents.



Design drop-in sessions: August 2010

24" ERGO[®] HINGED ASSEMBLY

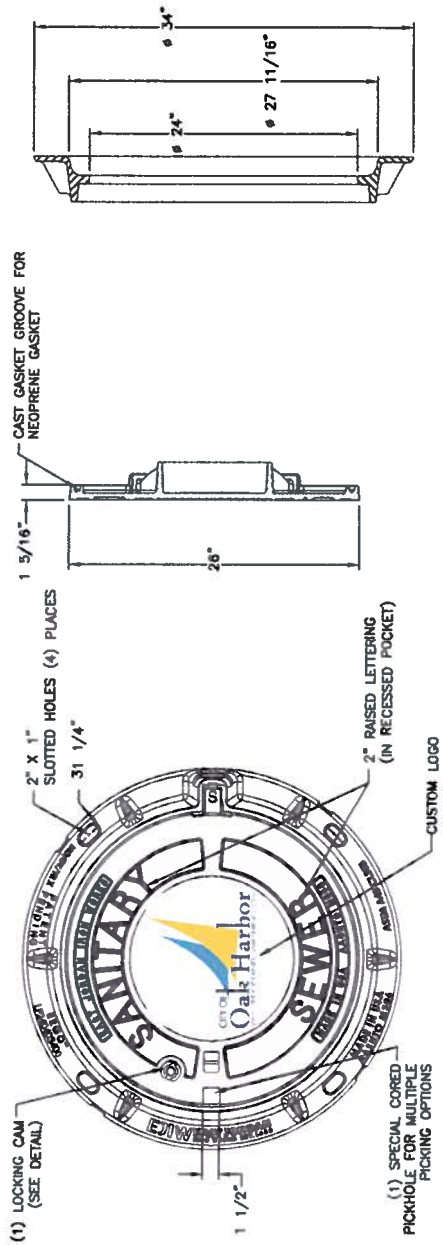

FRAME SECTION

COVER SECTION

PLAN VIEW

COVER SECTION

HINGE & GASKET VIEW

CAM LOCK VIEW

FRAME SECTION

HINGE POSITIONS

REFERENCE INFORMATION

LC00104XXX
LF240403400

DRAWING DETAILS

ORIGINAL DRAWING: SBB 07/15/10
REVISED BY:

Call Today for More Information

800.626.4653

EJIW EAST JORDAN
WE COVER YOUR INFRASTRUCTURE

www.ejiw.com
MADE IN THE USA

Weights (lbs./sq.) dimensions (inches/mm.), and drawings provided for your guidance.
We reserve the right to modify specifications without prior notice.
Uncontrolled distribution.

CONFIDENTIAL: This drawing is the property of East Jordan Iron Works, Inc. and embodies confidential information, registered marks, trade secret information, and/or know-how that is the property of East Jordan Iron Works, Inc. ©Copyright 2009 East Jordan Iron Works, Inc.

Corporate Headquarters
801 Spring Street
PO Box 439
East Jordan, MI 49727-0439
800.874.4100

